



SANTAK® ARRAY SERIES MODULAR UPS

ARRAY® 3A3™ PT

Modular UPS System Solution
25-800kVA



ARRAY 3A3 PT

ARRAY 3A3 PT is SANTAK's new generation modularized UPS. An ideal solution for a safe, reliable, stable and green UPS which satisfies any customer's one-stop demand to a basic power supply solution for their data center with its compatibility with the ARRAY series modular UPS.

The ARRAY 3A3 PT is SANTAK's latest three/three modularized, digitally controlled UPS. It is the realization of the latest electronics and automation control technology, a benchmark in the UPS market. The ARRAY 3A3 PT brings about a new concept in power supply solution, allowing a breakthrough in the practicability of power usage equipment. ARRAY 3A3 PT applies a tray type, smart modular design that allows for hot plug/play designs, this allows flexible adjustment of the modules to satisfy power and reliability requirements. Zero off line maintenance is also realized by its capability to conduct on line maintenance when modules are idle.

Power module rating: 25kVA/22.5kW

Power system rating: 25~200kVA Per Frame

External redundancy capacity: Parallel up to 4 frames for a total system size of up to 800kVA

Input voltage range: 214~520VAC

Input frequency range: 214~520VAC

Output voltage: 40~70Hz

Topology: Double conversion on-line technology, three-level bridge IGBT PWM control



ADVANCED MODULAR DESIGN

ARRAY 3A3 PT applies complete modularization with easy plug/play designs, system rack, UPS, communication, display modules and optional power distribution panels, smart cards and etc. allows for complete adherence to a customer's requirement. Each UPS module has a completely functional 25kVA UPS, advanced wireless parallel control technology and smart communication protocols, allowing the UPS, communication and display module to realized online maintenance that will not affect its daily operations. New modules can also be added to the system without need for calibration. Maintenance and expansion can be easily achieved.

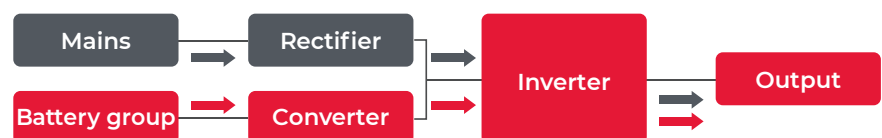

— Mains model — Battery model



FRIENDLY INTERFACE

ARRAY 3A3 PT provides easier access to detailed status information through its large, user-friendly 7" HMI touchscreen interface.

With the graphical HMI interface you can track stats on energy savings, battery time, outage tracking, load profiling and much more.

LEADING PARALLEL TECHNOLOGY

ARRAY 3A3 PT also supports parallel system connection that allows a maximum capacity of up to 800kVA. Parallel system connection uses the same set of batteries, each battery applies a 2V*216-252 section design, allowing flexibility to effectively use an existing battery system and allow for single removal of faulty battery set.



Paralleling with 4 units, up to 800kVA

EASY INSTALLATION

ARRAY 3A3PT's system rack applies a standard 2m x 19inch design, with parallel connecting components for UPS modules pre-installed, allowing additional UPS modules to operate in parallel upon plug in. This saves time, materials, manpower costs for traditional UPS parallel system expansions, while enhancing power usage safety and machine room clarity in addition to lowering the difficulty to maintenance and management, ultimately increasing the system's overall reliability.

- Based on the IT room's characteristic, customers can choose to go with easily installed under or overhead wire systems
- Easy installation while saving space
- System racks are supported with wheels and balance adjustment bases allowing for easy adjustment of positions on site



HIGH AVAILABILITY

THE MOST RELIABLE N+X WIRELESS PARALLEL REDUNDANT STRUCTURE

ARRAR 3A3 PT system level of N + X parallel redundancy can greatly improve the reliability of the UPS power supply, the adoption of leading wireless parallel control technology, compared with wired in parallel to reduce the single failure point (steady work also can work normally even if the parallel line fault), and improve the system reliability.

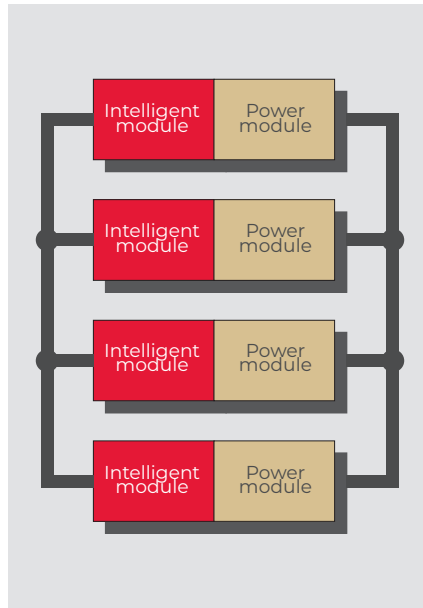
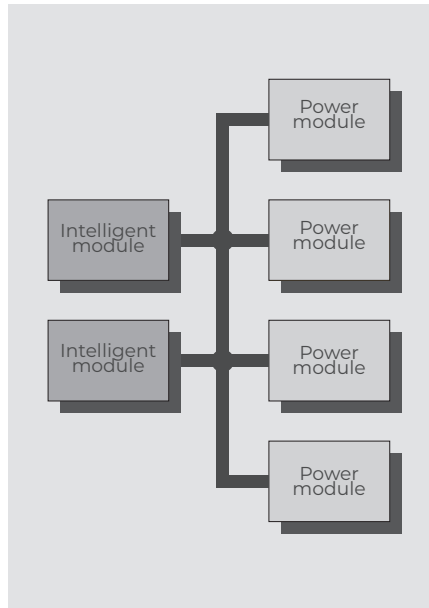

EXTREMELY HIGH LEVEL OF SYSTEM AVAILABILITY

ARRAY 3A3 PT adopts advanced N + X wireless parallel redundancy control technology, and each module are based on a full-fledged UPS, no additional control module to control the parallel system, all parallel functions are performed by UPS module itself, high reliability. According to the strict calculation, if the UPS redundant two modules above, the availability of UPS can reach 99.999% or more. The ARRAY 3A3 PT can handle even the most demanding load on the power supply.

MAINTENANCE TIME

As long as the parallel machine system is redundant (N+X, X>1), even if a UPS module fails, it will not affect the normal operation of the system, so the repair time (MTTR) in this case is zero; If the number of UPS modules with failure is greater than the number of redundant UPS modules, the maintenance time is not more than 5 minutes due to the replacement of UPS module.

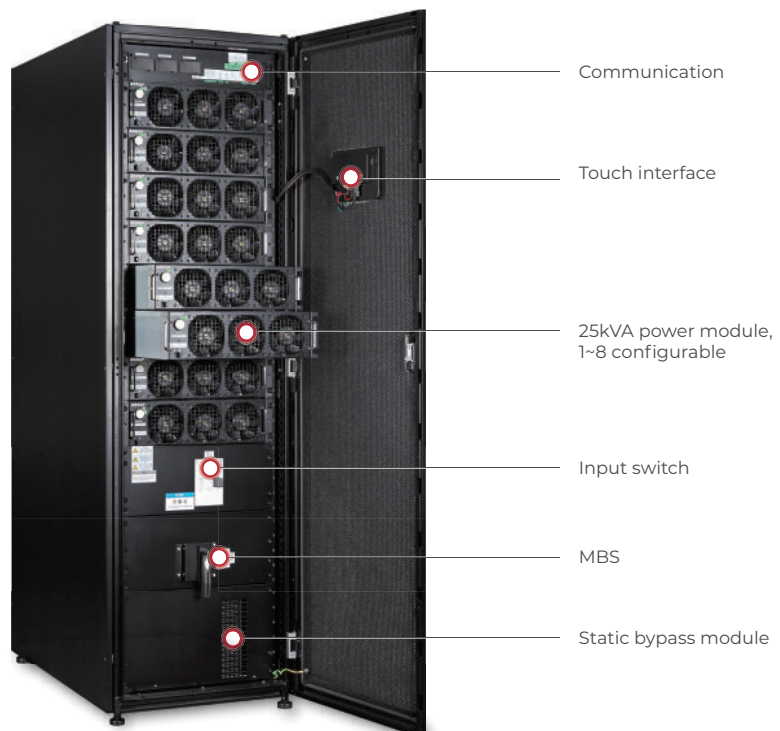

MAXIMUM ENERGY EFFICIENCY LOWEST TCO

The ARRAY 3A3 PT is simply the most efficient UPS in its class, offering the lowest Total Cost of Ownership. Thanks to Santak's advanced algorithms and energysaving features, ARRAY 3A3 PT achieves up to 99% efficiency. This efficiency is well proven with installations in major datacentre hubs in the Asia Pacific region and around the world.

99% EFFICIENCY - ECO

ECO mode enables the 3A3 PT efficiency to reach an impressive level of 99% by suspending the power modules when power conditioning is not required.

The power is fed through the static bypass switch, and in the event of exceeding pre-set input limits, the UPS is ready to switch to double-conversion mode in under two milliseconds. In addition to extremely low losses, the ECO mode provides filtering against fast low-energy transients. It is simply the most advanced, most reliable, fastest-reacting energy-saver architecture available.

In addition to saving energy, this technology enhances the reliability of the system by reducing electrical stress in the power electronic components, extending the UPS life time and thus reducing total cost of ownership.

SANTAK 3A3 PT EFFICIENCY IN ALL MODES

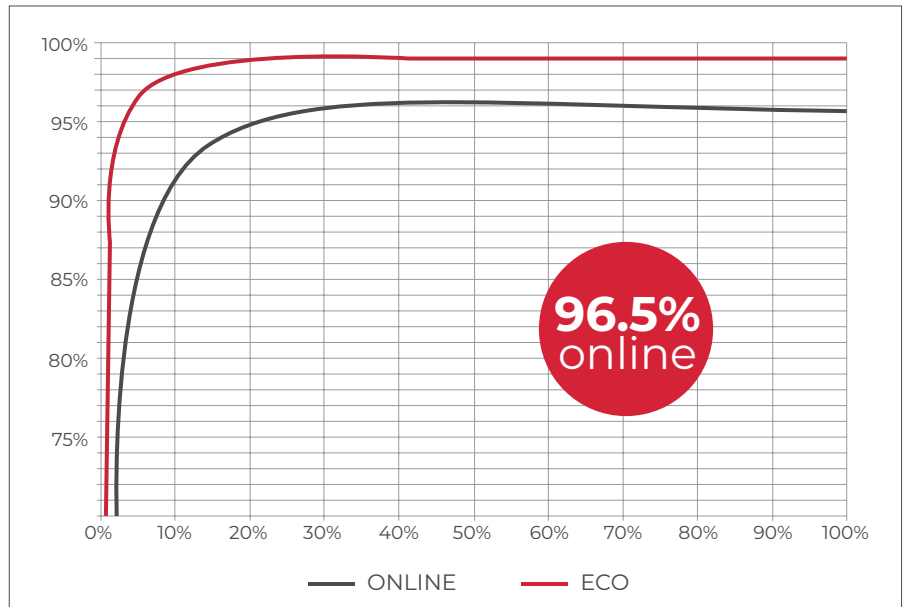

MAXIMUM DOUBLE CONVERSION EFFICIENCY

The 3A3 PT still offers the highest double conversion efficiency in the market, reaching above 96%.

HIGHEST POWER DENSITY

The unity power factor maximises the true available power of the 3A3 PT. This means it can deliver up to 20% more real power than other UPSs in its class.

The 200kVA frame can house an internal Maintenance Bypass Switch(MBS) and rectifier input switch.

The highly scalable nature of the 3A3 PT means that scaling up in response to increased demand takes minutes rather than hours. Scaling up can also be achieved without increasing the footprint – saving valuable floor space. The modular design allows for internal redundancy, which eliminates the need for an additional UPS for N+1 configurations.

External redundancy also improves scalability, by paralleling up to 4 frames for a total system size of up to 800kVA.



The 3A3 PT 25kW UPM (Uninterruptible Power Module)

ARRAY 3A3 PT APPLICATIONS:

Data Centers
Public Security Center
Bank Data System
Educational System
Tele-Com
Broadcast System
Industrial Control
Medical Center
Transportation
Others.....

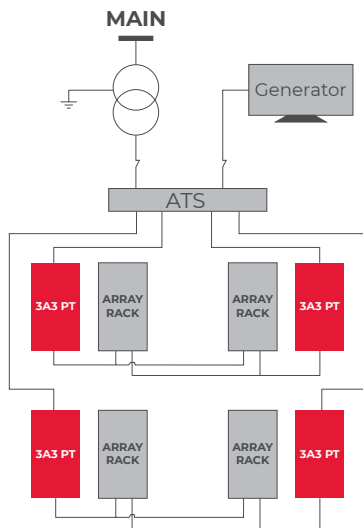

FLEXIBLE CONFIGURATION

Due to ARRAY 3A3 PT's complete modular design, within a single system rack the user can flexibly choose a suitable UPS system with a capacity ranging from 25kVA to 200kVA based on their requirements. Users can avoid the issue of a large initial investment in a UPS system by simply leaving extra capacity in switches and power cable in the first installation and install additional UPS modules when the need arises in the future. Allowing users to use their budget at the required timing.

SIMPLE CONTROLS

- Output voltage can be designated via touch screen: 220/ 230/ 240VAC, 220VAC (Default)
- Battery segments can be adjustment via the touch screen settings, supports adjustment of 36-42 battery segments
- Shutdown, setting password designations can be setup to avoid mis-control
- Saving and storing event logs, can store up to 4096 log messages

INTELLIGENT MANAGEMENT

The new web-based interface of the Intelligent Power software simplifies the usage, by allowing access through NMC, as well as RS232, RS485, USB and so on, realizing remote management via the internet.

SANTAK INTELLIGENT BATTERY MANAGEMENT TECHNOLOGY

3A3 PT adopts the advanced 3-stage charging technology. In the first stage, it charges the battery up to 90% capacity with high current. In the second stage, it charges the battery to 100% capacity with constant voltage. In the third stage, it stays in rest mode. The 3-stage charging method can extend the battery life cycle avoiding long-time floating charge issues. SANTAK intelligent battery management technology can accurately forecast battery working mode and remind your customers of potential malfunction.

Array® 3A3 PT UPS

25-800kVA Modular Solution

MINIMUM OVERALL SYSTEM COST WITH HIGH FUNCTIONALITY

Lowest Total Cost of Ownership (TCO)

- Under dual line conversion, the current advanced electronic technology allows for over 96% efficiency, effectively saving daily operation costs.
- AC Energy Conversion Optimization (ECO) system efficiency > 99%
- Flexible compact single unit solution

High Flexibility

- Patented wireless parallel connection technology, high reliability removing single point malfunction necks
- Hot plug/play UPS modules
- Concentrated static network modules that allow system expansion via utilizing initially installed networks based on real N+X demands
- Standard system design maintenance channels ensures greatest system power factor reliability, allowing for adaptable load without lowering capacity
- SANTAK smart battery charge technology effectively lowers the battery wear and elongates battery lifetime
- Wide battery input range, no neutral line design for battery input, saving costs

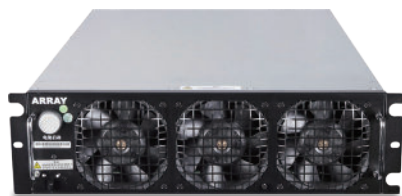

25kVA Module



75kVA hot-swappable static switch bypass module * only for 75kVA frame

High Expandability and Easy Installation

- Maximum 4 unit horizontal expansion, 25kVA ~ 800kVA
- Lowers CapEX by its high expandability, modularized design and “Investment along Growth” characteristic
- Hot plug/play technology allows for a lowest MTTR (Average maintenance time <10mins), 19 inch standard system rack design for easy management

Easy Management

- Various optional smart cards (Web/SNMP, Modbus/Jbus, dry node)
- SANTAK WinPower software surveillance management
- Large interactive display touch screen and visualized data for clear presentation of the UPS's operation status

Application References

- Small & Medium Data Center
- Bank
- Small & Medium Enterprises
- Medical Equipment
- Tele-Com
- Process Control

ARRAY 3A3 PT 25-200kVA

Model	Description	Dimension (W*D*H) mm	Weight (Kg)
UPM	25kVA/22.5KW power module	439*595*130	27.5
3A3 PT-75-MBS	3A3 PT 75KVA Frame with MBS	600*1100*2020	262
3A3 PT-200-MBS	3A3 PT 200KVA Frame with MSB	608*1010*2050	368

ARRAY 3A3 PT UPS Technical Specifications

General	
UPS output power rating	25-200kVA, 0.9pf
Efficiency in double conversion mode	>96%
Efficiency in Energy Saver System	>99%
Topology	Double conversion on-line technology, three-level bridge IGBT PWM control
External paralleling	up to 4 units with Hot paralleling technology
Noise @1m, 25°C	< 65 dBA in double conversion
UPS topology	Double conversion
Dimensions (WxDxH) mm	600mm x 1100mm x 2020mm (75kVA Frame) 608mm x 1010mm x 2050mm (200kVA Frame)
Degree of protection	IP20
Altitude (max)	1000m above sea level at 40°C

Input	
Input wiring	3ph + N + PE
Rated input voltage	220/380, 230/400, 240/415 V
Rated input frequency	50 or 60 Hz, user configurable
Frequency tolerance	40 to 72 Hz
Input power factor at 100% load	0.99
Input THD	<3%
Soft start capability	Yes

Battery	
Battery type	VRLA, AGM, GEL
Charging method	Intelligent Battery Management or Continuous Float
Temperature compensation	Optional
Battery quantity	36 to 42 blocks. Default is 40 blocks
Battery start capability	Yes

* Display panel supports English, French, Portuguese, Spanish and Russian

Output	
Output wiring	3ph + N + PE
Rated output voltage rating	220/380, 230/400, 240/415 50/60 Hz
Output THD	<1.5% (100% linear load); <3% (100% non-linear load)
Permitted load power factor	0.8 lagging to 0.8 leading
Overload on inverter	10 min 125% 60 sec 150% 300 ms > 150%
Overload on battery	10 min 125% 60 sec 150% 300 ms > 150%
Overload on bypass	Continuous < 115%, 10 ms 1000%

Communications	
Minislot	3 communication bays
Serial ports	Built-in host and device USB
Standard connectivity ports	5 building alarm inputs and a dedicated EPO
Software	Santak WinPower

Compliance with standards	
Safety	IEC 62040-1
EMC	IEC 62040-2
Performance	IEC 62040-3
RoHS	EU directive 2011/65/EU

* Due to continuous product improvement programs, specifications are subject to change without notice.



SANTAK ELECTRONIC (SHENZHEN) CO., LTD.

Shenzhen, P.R. China
Address: No. 8 Baoshi Road, Baoan
District, Shenzhen, 518101

Tel: 0086 755 27572666
Fax: 0086 755 27572730 (27572480)
Email: santakexport@santak.com

Website: www.santak.com

July, 2021 EN-00114-01